

Einbauanleitung – Fertigteil Baustelle

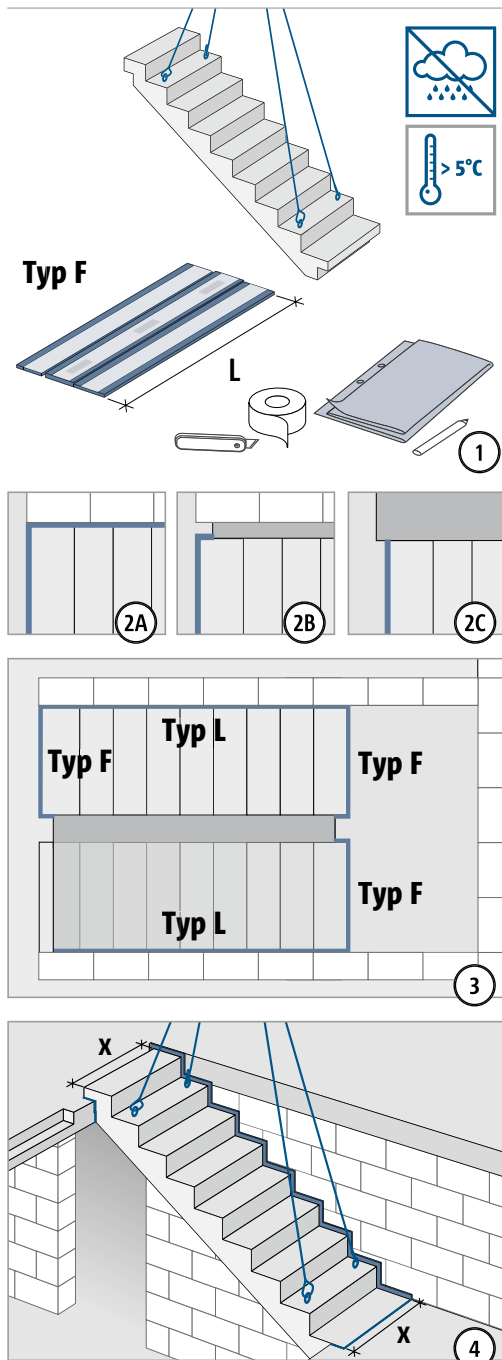

x (mm)	1 × Typ F	2 × Typ F	3 × Typ F	...
L900	750–900	1500–1800	2250–2700	...
L1000	900–1000	1800–2000	2700–3000	...
L1100	1000–1100	2000–2200	3000–3300	...
L1200	1100–1200	2200–2400	3300–3600	...
L1300	1200–1300	2400–2600	3600–3900	...
L1500	1300–1500	2600–3000	3900–4500	...

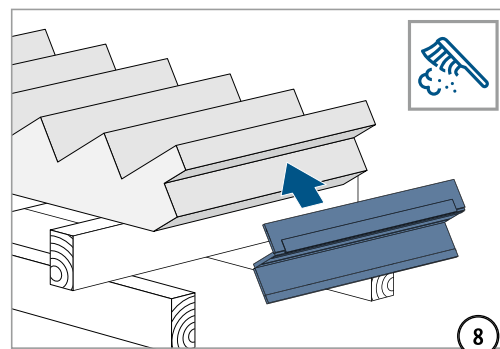
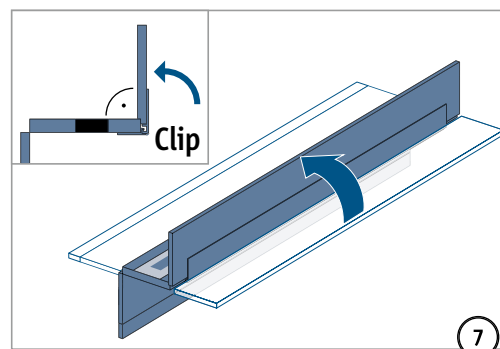
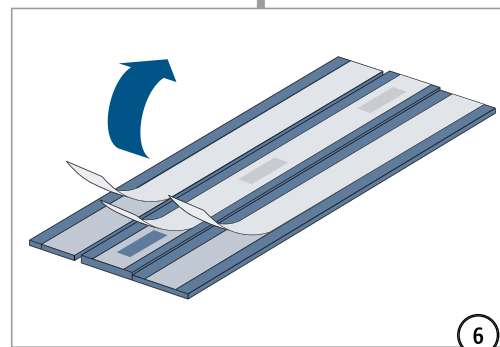
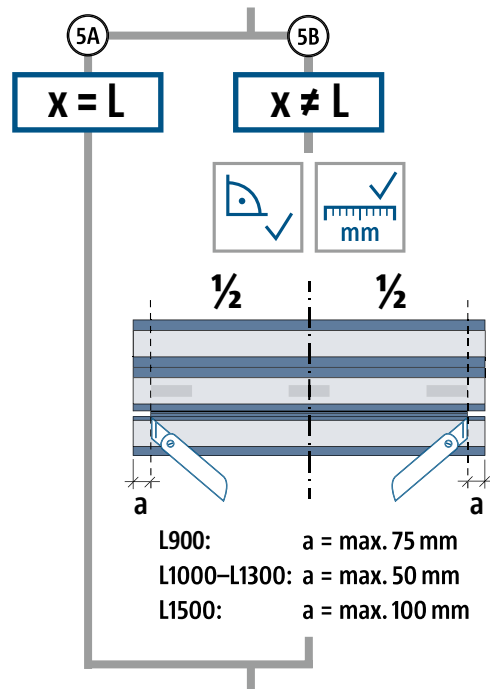

Einbauanleitung – Fertigteil Baustelle

Typ L

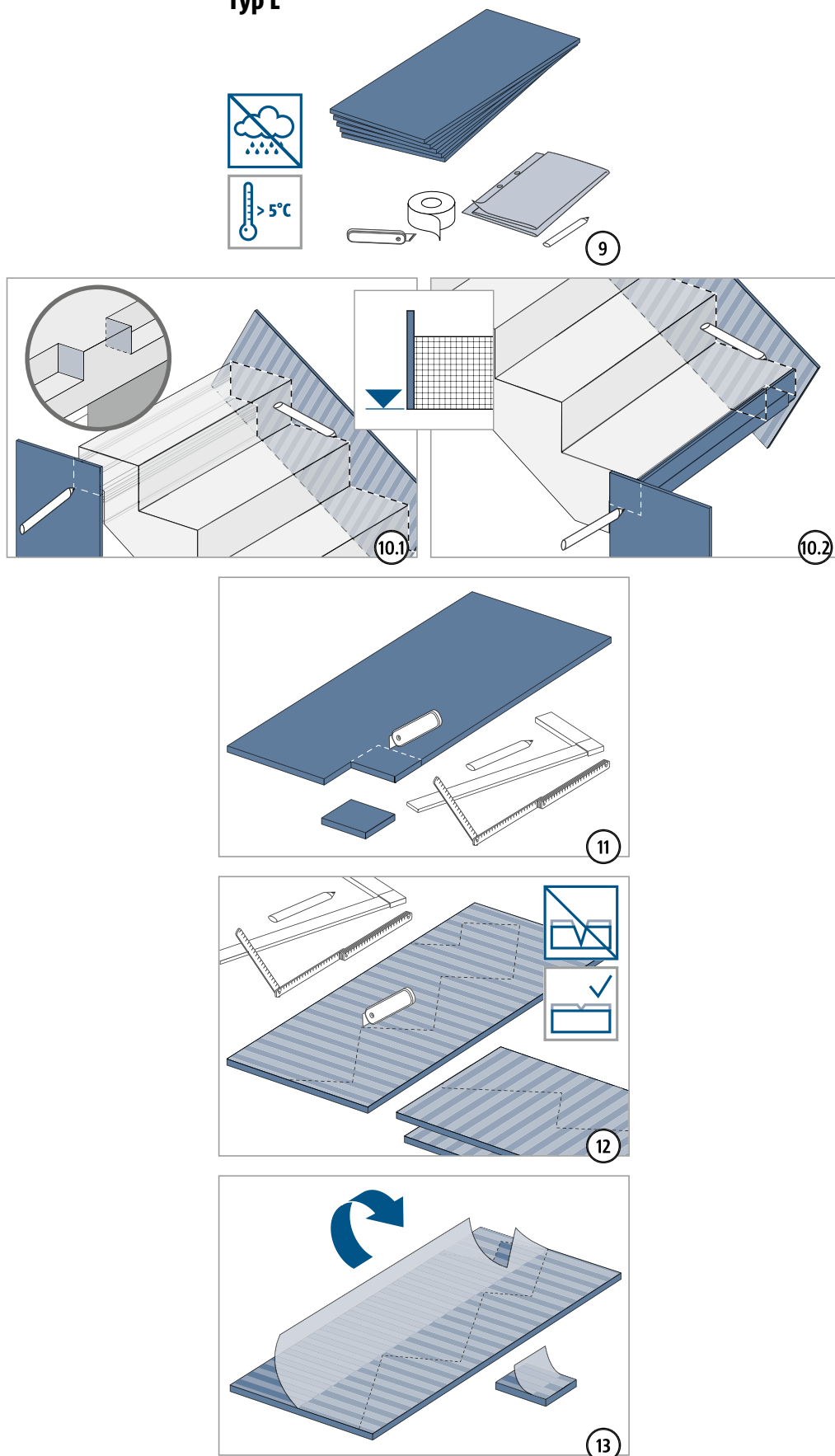

Einbauanleitung – Fertigteil Baustelle

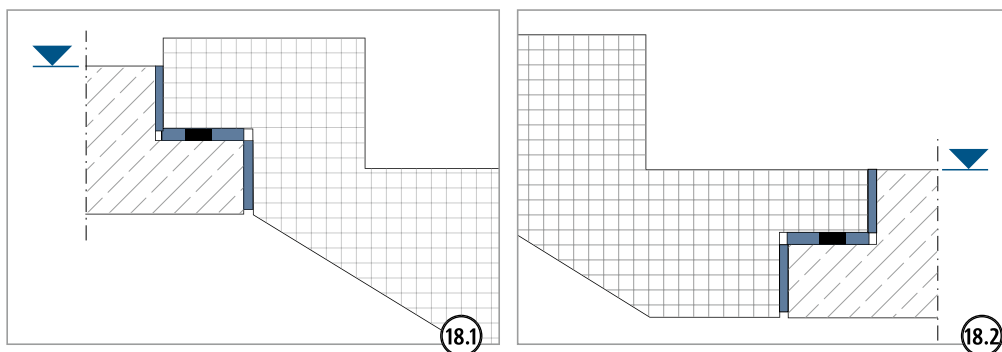
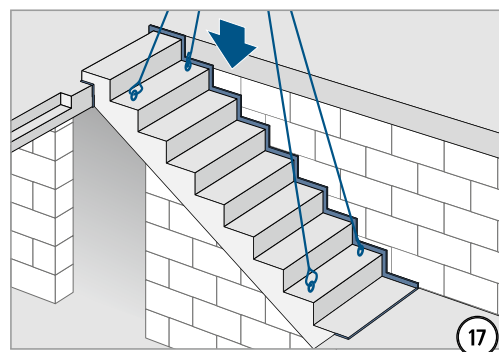
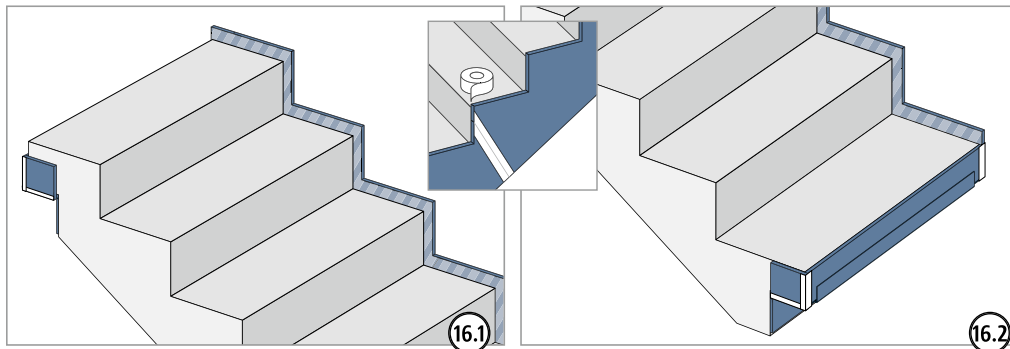
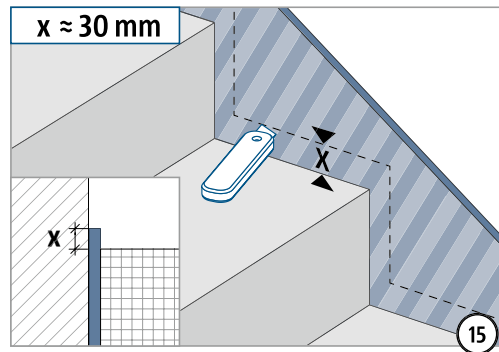
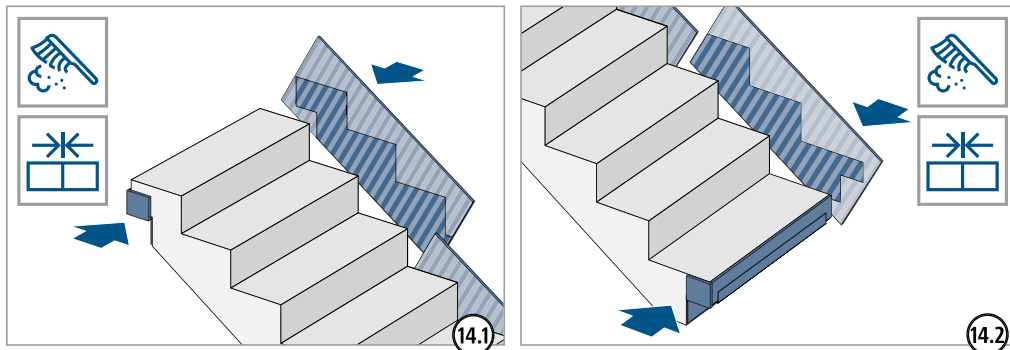

Einbauanleitung – Fertigteil Baustelle

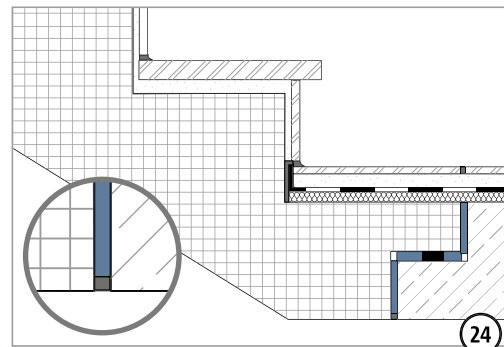
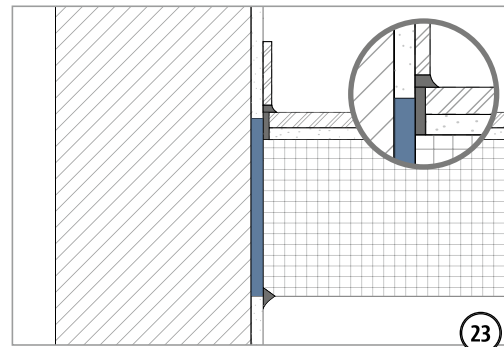
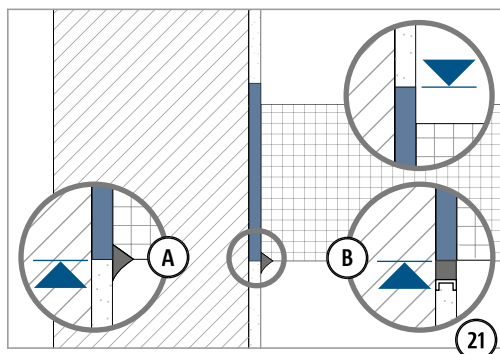
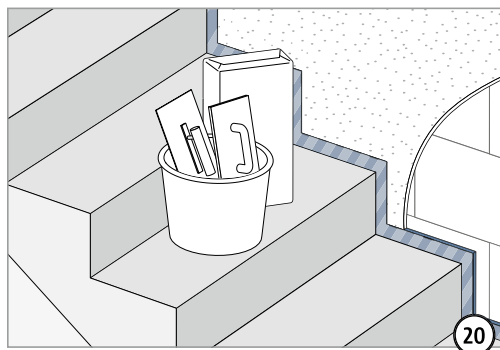
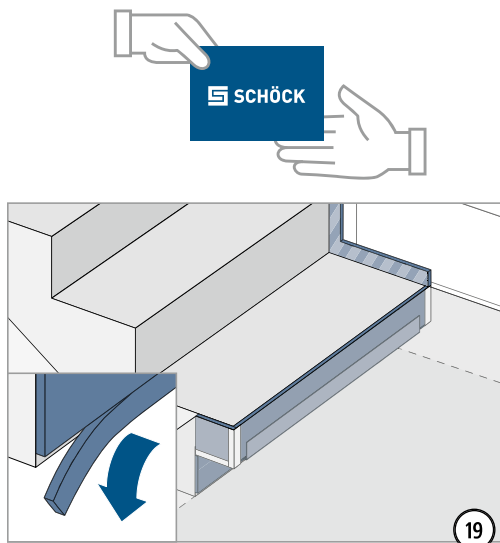

Einbauanleitung – Fertigteilwerk

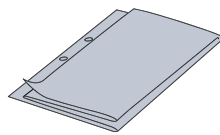
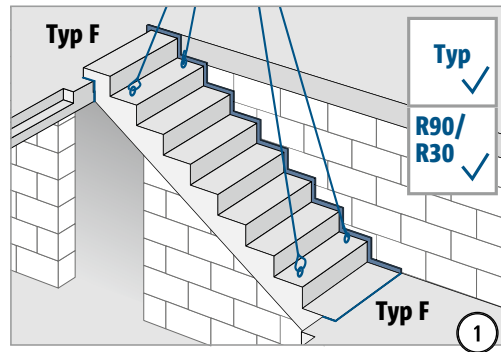

$h_{k,l} \geq 80 \text{ mm}$
 $K_T: 130\text{--}160 \text{ mm}$
 $c_v: 15 \text{ mm}$

Tronsole® Typ F	V1	V2	V3
R30	$x_1 = 150 \text{ mm}$	$x_1 = 150 \text{ mm}$	$x_1 = 150 \text{ mm}$
R90	$x_1 = 150 \text{ mm}$	$x_1 = 100 \text{ mm}$	$x_1 = 100 \text{ mm}$

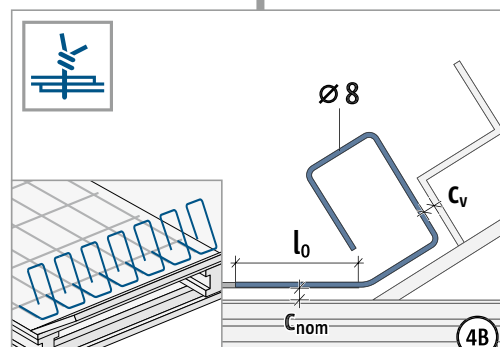
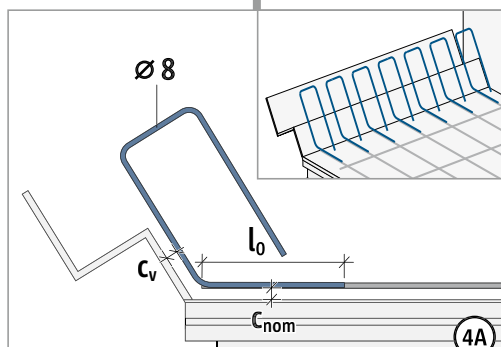
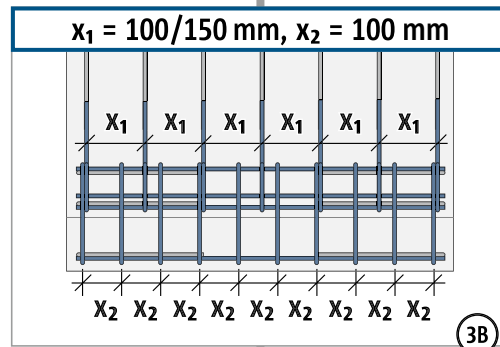
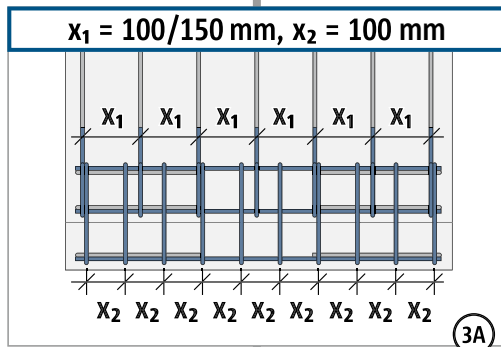
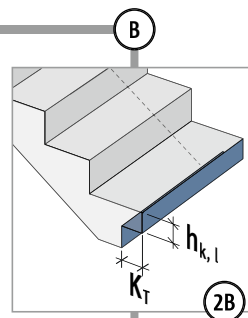
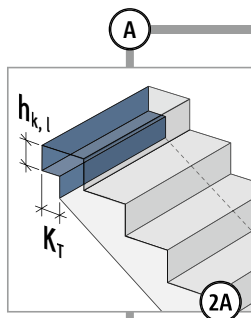

F

Einbauanleitung – Fertigteilwerk

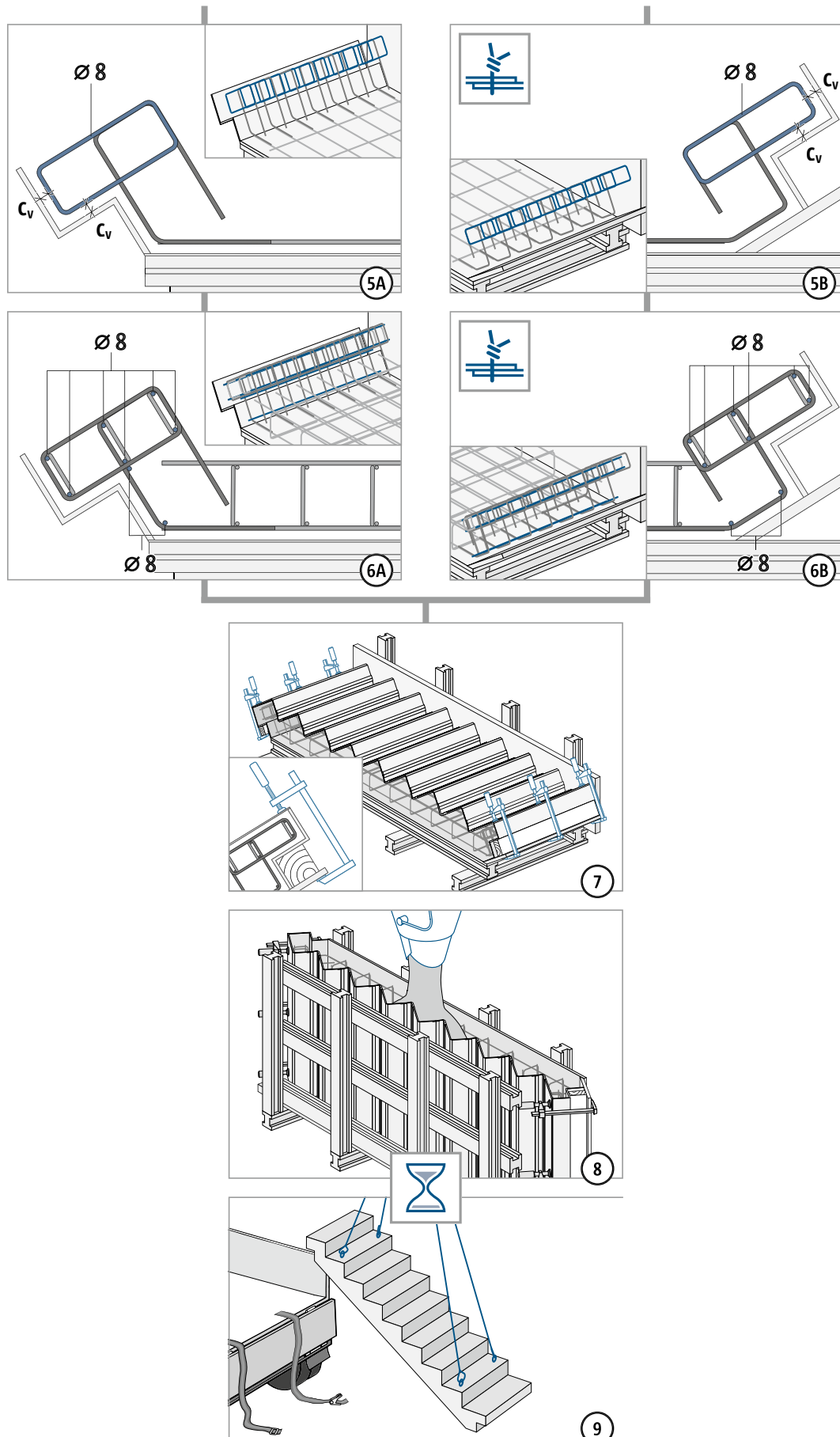

F