

# Fire protection

## Fire protection configuration | Fire protection classes

### Fire protection configuration Schöck Isokorb® CXT

The Schöck Isokorb® CXT comes standard with a fire protection configuration (REI 120).

- e.g. CXT type K-E-M4-V1-REI120-CV26-H180-L500-1.1

Fire protection requirements that apply to the building component also apply to the product that is to be used. Prerequisite for the fire protection classification of the balcony connection is that the balcony slab and the floor also fulfil the requirements on the necessary fire resistance class according to SS EN 1992-1-1 and SS EN 1992-1-2 (EC2). If, in addition to the load-bearing capacity (R), integrity (E) and insulation (I) are also required in case of fire, then the block-outs between the Schöck Isokorb® CXT are to be closed, e.g. using the Schöck Isokorb® XT type Z with fire protection.

The Schöck Isokorb® CXT has been tested in room closure configuration in accordance with the requirements for ceilings according to SS-EN 1365-2. The basis for this test is SS-EN 1365-5. The fire protection of the Schöck Isokorb® is additionally further tested on the basis of ceilings according to SS-EN 1365-2. This results in the classification REI (R – load-bearing capacity, E – integrity, I – insulation under the influence of fire).

The requirement from the fire tests with Schöck Isokorb® with flush integrated lateral fire protection bands or 10 mm projecting fire protection boards has been implemented. The integrated fire protection bands made from material forming insulation layers or respectively the 10 mm projecting fire protection boards on the upper side of the Schöck Isokorb® CXT ensure that the joints, which have opened due to the effect of the fire, are closed. Thus the room integrity and the insulation in the case of fire are ensured (see figures below).

The fire protection configuration of the respective Schöck Isokorb® type is presented in the product chapter subject “Fire protection configuration”.

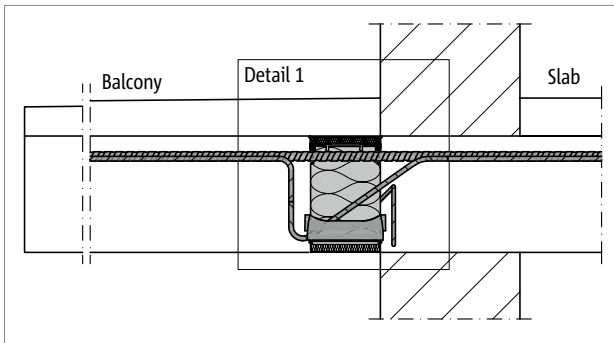

Fig. 4: Schöck Isokorb® CXT type K-E with REI120: Fire protection board top and bottom; lateral integrated fire protection bands

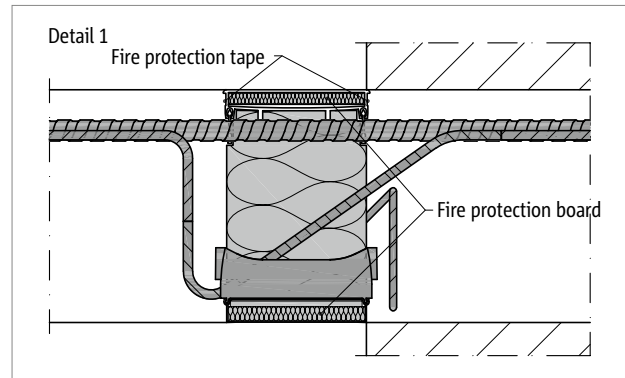

Fig. 5: Schöck Isokorb® CXT type K-E with REI120: Detail 1

### Schöck Isokorb® CXT with fire protection

For Schöck Isokorb® CXT the fire protection class of the connected reinforced concrete slabs depends on the concrete cover CV and the height of mineral floor coverings.

The Schöck Isokorb® CXT with fire protection (-REI120) has achieved fire protection class REI120 when exposed from below.

A reinforced concrete slab (balcony slab, floor slab) with a Schöck Isokorb® CXT type K-E-REI120-CV26 with fire effects from above achieves the fire protection class REI 30. With a Schöck Isokorb® CXT type K-E-REI120-CV46 REI 60 is achieved. See fire protection class page 15.

Basis for the fire protection classification of the Schöck Isokorb® CXT are the following documents:

- Approval Schöck Isokorb® XT-Combar Z-15.7-320
- Approval Combar® Z-1.6-238
- Expert opinion S6\_1-16-056 IK Combar ETK Fire in floor superstructure, MFPA Leipzig dated 25.11.2016 DE

Prerequisite for the fire protection classification of the balcony connection is that the balcony slab and the floor slab also meet the requirements on the required fire resistance class according to SS-EN 1992-1-1 and -2 (EC2).

Schöck Isokorb® CXT type	K-E-CV26	K-E-CV46
Fire resistance class	REI 120 from below and REI 30	REI 120 from below and REI 60

## Fire-resistance classes | Balcony fire protection classes

### Balcony fire protection classes with Schöck Isokorb® CXT type K-E-REI120

The following applies for balconies with fire load:

Higher fire protection classes are achieved through screed or mineral flooring materials of the floor slab or balcony slab. Depending on the flooring material various different heights are required (see table). Further materials in the floor screed have a positive effect which is not taken into account (analogous to SS-EN 1992-1-2 Fig. 5.7).

Schöck Isokorb® CXT type	Reinforced concrete slab with K-E-CV26			
Flooring material height $h_1$ [mm]	REI 30	REI 60	REI 90	REI 120
Screed	not required	20	35	50
Anhydride screed	not required	25	45	60
Cement screed (SS-EN 1992)	not required	25	40	55
Mastic asphalt screed	not required	25	35	50
Dense bed of grit	not required	25	35	45
Bed of grit with concrete slabs	not required	25	40	55

Schöck Isokorb® CXT type	Reinforced concrete slab with K-E-CV46			
Flooring material height $h_1$ [mm]	REI 30	REI 60	REI 90	REI 120
Screed	not required	not required	20	30
Anhydride screed	not required	not required	20	30
Cement screed (SS-EN 1992)	not required	not required	15	30
Mastic asphalt screed	not required	not required	10	25
Dense bed of grit	not required	not required	10	20
Bed of grit with concrete slabs	not required	not required	15	30

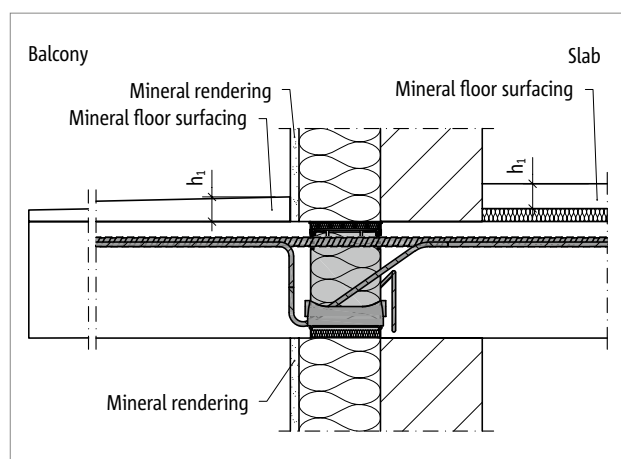

Fig. 6: Schöck Isokorb® CXT type K-E-REI120: Flooring material for higher fire protection classes

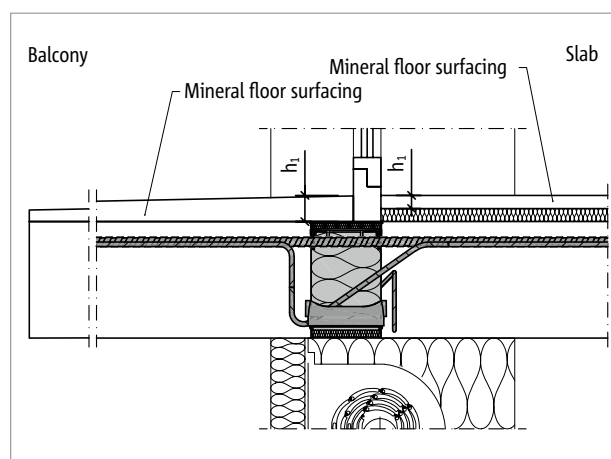

Fig. 7: Schöck Isokorb® CXT type K-E-REI120: Flooring material for higher fire protection classes

### i Fire protection class

- REI 90 (floor building class 5) is achieved with Schöck Isokorb® CXT type K-E-REI120-CV26 and for example 40 mm cement screed flooring material on the floor.
- Depending on the required fire protection, in addition to the Schöck Isokorb® CXT type K-E-REI120 the required flooring screed is to be put out to tender.

## Balcony fire protection classes

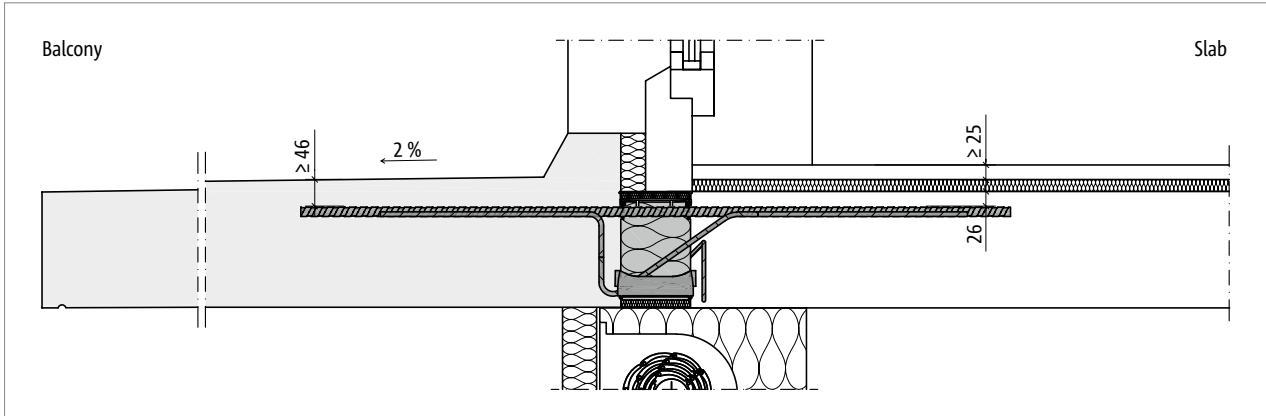

Fig. 8: Schöck Isokorb® CXT type K-E-REI120: Precast unit with higher concrete cover and flooring material inside for fire protection class REI 60

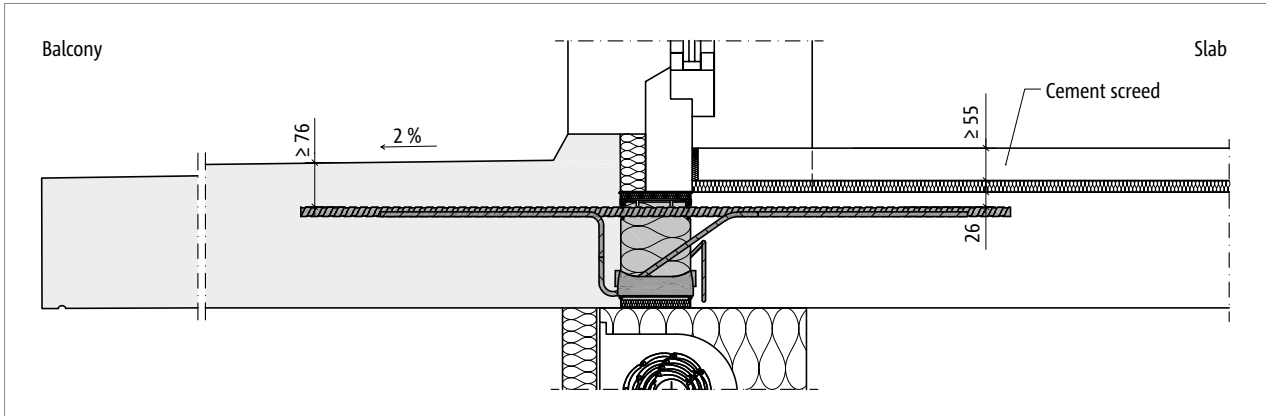

Fig. 9: Schöck Isokorb® CXT type K-E-REI120: Precast unit with higher concrete cover and flooring material inside for fire protection class REI 120

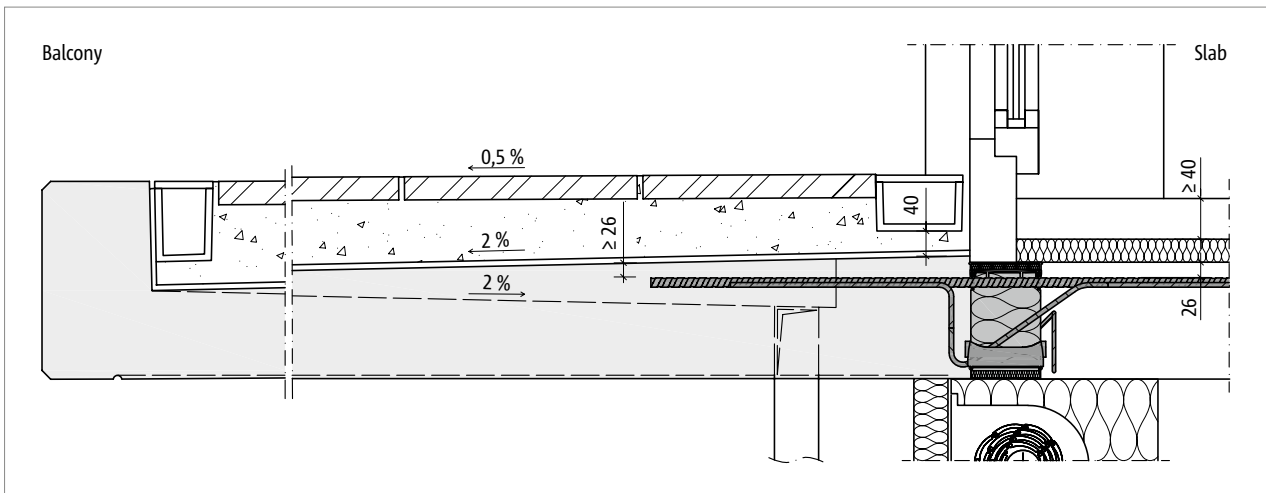

Fig. 10: Schöck Isokorb® CXT type K-E-REI120: Precast unit with flooring material and channel for fire protection class REI 90

## Fire resistance classes of passageway walks

### Fire protection classes for passageway walks using Schöck Isokorb® CXT type K-E-REI120

Escape route without fire load:

With the aid of numerical simulations a realistic for an enclosed room fire scenario with fire from above was investigated (Expertise BB-19-001-1, Ingenieurbüro IBB Hauswaldt, Germany).

The assumed heat release rate is 350 kW/m<sup>2</sup> (in comparison: according to SS-EN 1991-1-2: 2010-12 a heat release rate of only 250 kW/m<sup>2</sup> is to be assumed for dwellings, hospital rooms, hotel rooms, libraries, offices, classrooms, shops, shopping centres as well as for the transport branch.)

The escape route has to be free of fire load, the flames can, however, drive out of doors and windows. Rays of heat from the fire affect the passageway walk slab in front of openings in the wall.

The mean value of the investigated temperature of the reinforced concrete slab without floor cover reached the critical temperature limit only after 90 minutes of exposure to fire. The critical temperature limit at the surface of the tension bars of the Schöck Isokorb® CXT with CV26 concrete cover is only reached at isolated points.

Normal room fires end significantly before the sixtieth minute of the fire. Therefore a compound breakdown of the slab connections in the passageway walk due to a realistic fire event in the building can be excluded. Under realistic fire conditions, passageway walks can withstand ninety minutes without floor covering.

In this sense the protective targets of fire resistance, such as load-bearing capacity, are met in the case of fire.

Within the building, depending on the required fire protection, a flooring material with a height of  $h_1$  is required:

Schöck Isokorb® CXT type K-E	Concrete cover CV26		
Flooring material height at	Fire resistance class reinforced concrete slab access balcony		
	REI 30	REI 60	REI 120
Flooring material, floor side	$h_1$ [mm]		
Anhydride screed	not required	25	45
Cement screed (SS-EN 1992)	not required	25	40
Mastic asphalt screed	not required	25	35

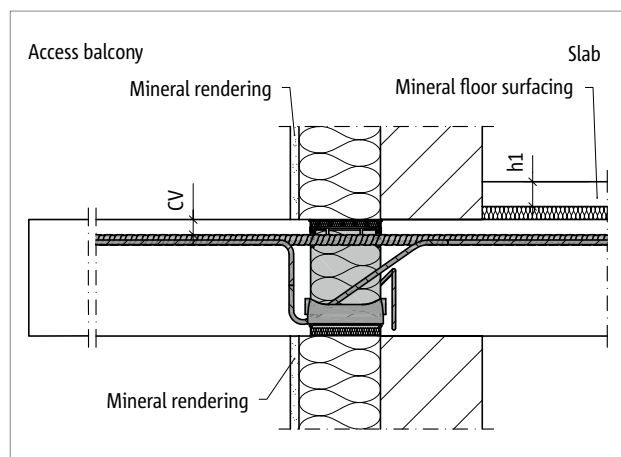

Fig. 11: Schöck Isokorb® CXT type K-E-REI120-CV26: Floor with flooring material; fire protection class of the passageway walk up to REI 90

#### **i** Fire protection class

- REI 90 (floor building class 5) is achieved with Schöck Isokorb® CXT type K-E-REI120-CV26 and for example 40 mm cement screed flooring material on the floor.
- Depending on the required fire protection, in addition to the Schöck Isokorb® CXT type K-E-REI120 the required flooring screed is to be put out to tender.

## Fire protection configuration for passageway walks

### ■ Sound insulation

- For sound insulation, check whether a floor covering is required on the passageway walk.

### Schöck Isokorb® in the escape route

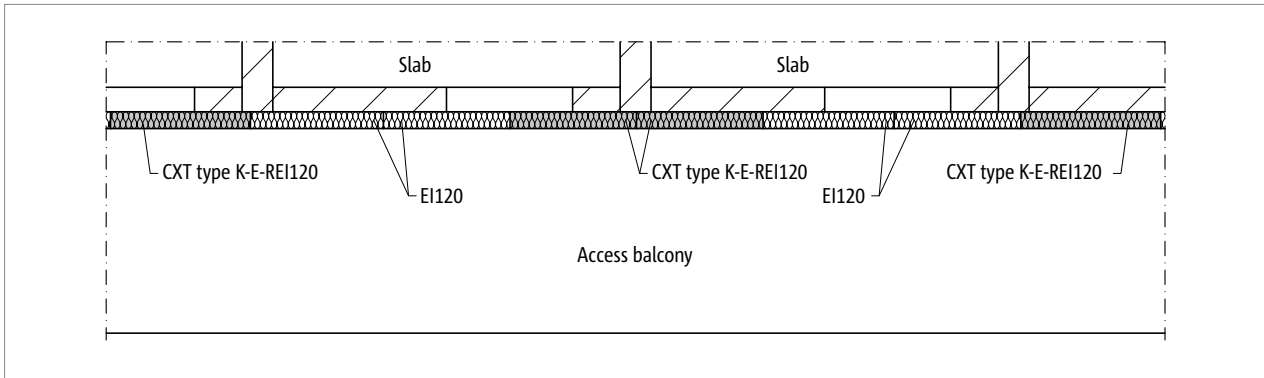

Fig. 12: Schöck Isokorb® CXT type K-E-REI120: passageway walk, room enclosing

### ■ Fire protection configuration

- Prerequisite for the fire protection classification of the escape route is that the passageway walk slab and the intermediate floor also meet the requirements on the required fire resistance class according to SS EN 1992-1-1 and -2 (EC2).
- If, in addition to the load-bearing capacity (R), integrity (E) and insulation (I) are also required in case of fire, then the block-outs between the Schöck Isokorb® are to be closed, e.g. using the Schöck Isokorb® T type Z fire protection configuration.