

Building physics

Thermal insulation of the Schöck Isokorb® CXT

The Schöck Isokorb® thermally separates the concrete in the exterior from that in the heated interior. The individual components of the Schöck Isokorb® simultaneously provide thermal insulation and transfer internal forces: The insulating element ensures the thermal insulation. Pressure bearings, shear force bars and tension bars are available for the transfer of internal forces.

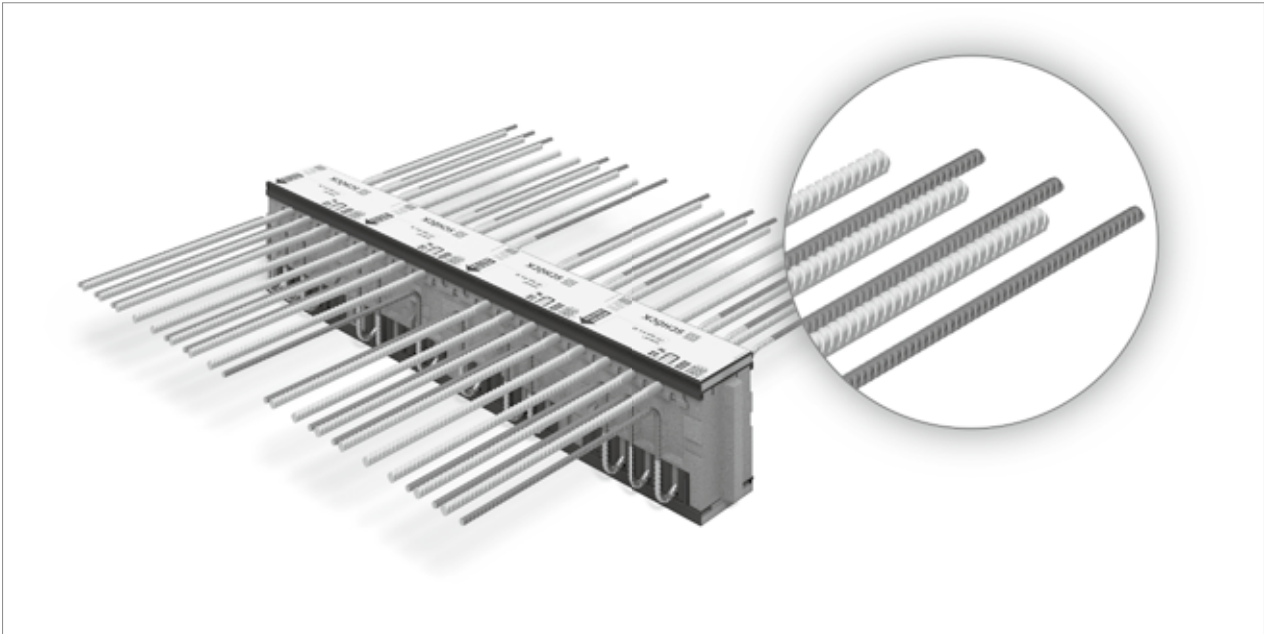

The material and the geometry of each of these components are crucial for the energy losses through the thermal bridge. Due to different thermal conductivities, each component has a different influence on the total thermal conductivity, depending on its share of the total cross-section.

Each of the components is tailored to these tasks: The pressure bearings are made from an optimised micro-steel fibre reinforced high performance fine concrete. Stainless steel with a low thermal conductivity is used for the shear force bars in the area of the penetration of the thermal insulation.

The technological innovation of the Schöck Isokorb® CXT is the use of the innovative material component Combar® for tension bars.

Tension bars of the Schöck Isokorb® CXT

The tension bars of the Schöck Isokorb® CXT type K-E are made of Combar®. Combar® is a fibre-composite material and is characterised through a very low thermal conductivity of 0.9 W/(m·K). In comparison to stainless steel with about = 15 W/(mK), the thermal conductivity of the tension bars is reduced by more than 94 %.

Due to the optimised material properties of the tension bar, the proportion of the overall heat loss is thus massively reduced through the Schöck Isokorb (see figure).

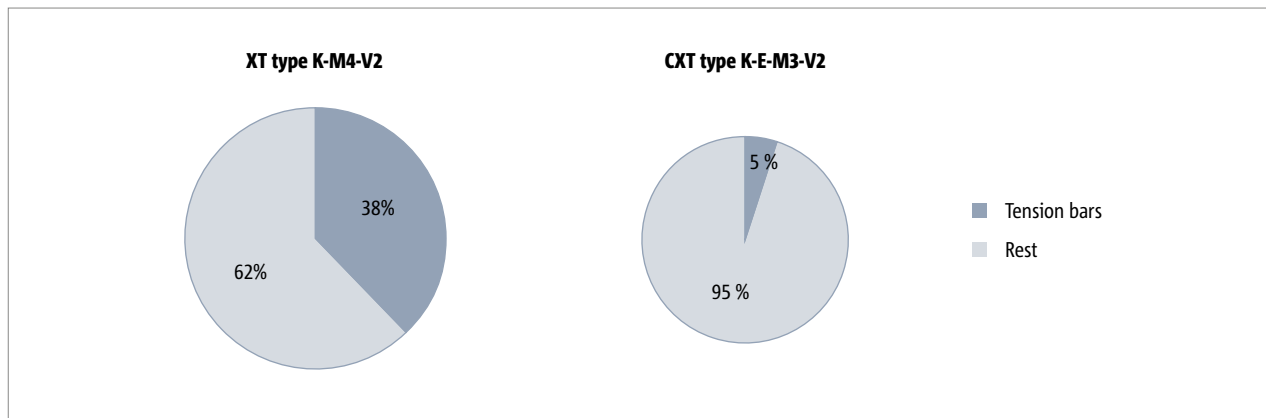

Fig. 1: Proportion of the tension bars and other components in the λ_{eq} -value of the Schöck Isokorb® XT type K-M4-V2 and CXT type K-E-M3-V2

The proportion of the tension bars in the equivalent thermal conductivity of the overall Schöck Isokorb® in this example of the Schöck Isokorb® CXT type K-E-M3-V2 in comparison with the Schöck Isokorb® XT type K-M4-V2 of 38 % falls to 5 % through the replacement of steel tension bars by Combar®.

The reduction becomes noticeable in the overall thermal conductivity of the Schöck Isokorb® CXT type K-E. As the thermal conductivity of the Schöck Isokorb® is dependent on the shape and the material of the respective component parts, one can observe a significant reduction of the thermal conductivity of the overall insulation element.

Thus the Schöck Isokorb® CXT is a highly efficient form of thermal separation and, with a high thermal insulation performance is optimally suited for installation in buildings with high energetic requirements up to the Passive House level.

Compared to stainless steel, Combar® also has a considerably lower energy requirement during production. Thanks to the improved eco-balance (+27 % less CO₂ emission) the Schöck Isokorb® CXT makes a sustained contribution to climate protection.

Detailed examination of thermal bridges

Due to its particularly high insulation performance, the Schöck Isokorb® CXT is ideal for energetically high-performance building projects. The insulation quality of the Schöck Isokorb® CXT has a great influence, in particular with detailed thermal bridge considerations. The insulation quality is described by the product-specific thermal conductivity λ_{eq} .

The equivalent thermal conductivity λ_{eq} is the overall thermal conductivity of the Schöck Isokorb® determined across the various surface parts and, with the same insulation element thickness, is a measure for the thermal insulation effect of the connection. The smaller λ_{eq} , the more high-quality the insulation of the balcony connection. As the equivalent thermal conductivity takes into account the proportion of the materials used, λ_{eq} is dependent on the load-bearing level of the Schöck Isokorb®. The λ_{eq} value can then be used for the comparison of various products or for a detailed thermal bridge calculation.

When modelling a balcony connection in the conventional thermal bridge programme, the existing Schöck Isokorb® made out of several materials, can be modelled with the aid of λ_{eq} , simplified as homogenous, cuboid replacement insulation element with the same dimensions, see figure. This replacement insulation element is then assigned as the “equivalent thermal conductivity” λ_{eq} for the calculation.

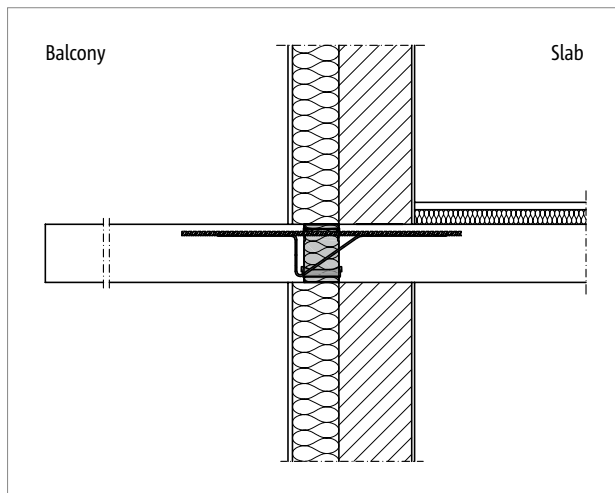

Fig. 2: Representation of a sectional drawing with detailed Schöck Isokorb® model

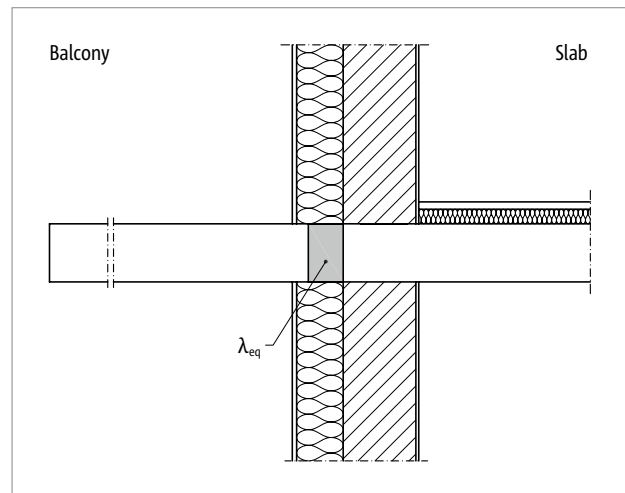

Fig. 3: Representation of a sectional drawing with substitute insulating element

The individual λ_{eq} values can be found online at:
www.schoeck.com/nedlasteringer/no