



ICC-ES Evaluation Report

ESR-4656

Reissued April 2022

This report is subject to renewal April 2024.

DIVISION: 03 00 00—CONCRETE
Section: 03 15 00—Concrete Accessories
Section: 03 21 00—Reinforcing Bars

REPORT HOLDER:

SCHÖCK USA, INC.

EVALUATION SUBJECT:

SCHÖCK BOLE SR STUD RAILS

1.0 EVALUATION SCOPE

Compliance with the following codes:

2018, 2015, 2012 and 2009 *International Building Code*® (IBC)

Property evaluated:

Structural

2.0 USES

The Schöck Bole SR Stud Rails are used as shear reinforcement in flat concrete slabs and footings to replace stirrups, drop panels or column capitals in increasing the punching shear resistance of the flat slabs and footings.

3.0 DESCRIPTION

3.1 General:

The 10-, 12-, 16- and 20-mm size Schöck Bole SR Stud Rails are forged double-headed deformed steel bar shear studs that are tack welded to steel bars. See Figure 1.

The Schöck Bole SR Stud Rail sizes and dimensions are shown in Table 1.

The Schöck Bole SR Stud Rails shall be used where designs are required to comply with ASTM A1044-2016a and Section 20.5 of ACI 318-14 (referenced in the 2018 and 2015 IBC). For applicable section references to earlier versions of ACI 318, see Table 2.

3.2 Materials:

3.2.1 Schöck Bole SR Stud Rails: The 10, 12, 16 and 20-mm Schöck Bole SR Studs are formed from round deformed steel bars conforming to the B500B steel specification and meeting the following strength requirements of ASTM A1044-2016a.

Yield strength: 51,000 psi (350 MPa), minimum.

Tensile strength: 65,000 psi (450 MPa), minimum.

Elongation in 2-inch (51 mm): 20 percent, minimum.

Reduction in area: 50 percent, minimum.

3.2.2 Steel Bars: The steel bars are not structural components of the Schöck Bole SR Stud Rails and are only intended for maintaining proper alignment, direction and spacing only. The steel bars conform to the B500B steel specification.

3.2.3 Stud Welding: The Schöck Bole SR Stud Rail double-headed shear studs are tack welded by Schöck to the steel bars in accordance with the approved Schöck quality documentation. All welding of double-headed shear studs complies with ASTM A1044-2016a and AWS D14.4 requirements.

4.0 DESIGN AND INSTALLATION

4.1 Design:

4.1.1 General: Structural design and installation of the Schöck Bole SR Stud Rails used as punching shear reinforcement in reinforced concrete slabs or footings must comply with the applicable provisions of ACI 318. Structural design and installation of the Schöck Bole SR Stud Rails used as punching shear reinforcement in reinforced concrete slabs or footings must comply with ACI 318 requirements shown in Table 4. The yield strength of transverse reinforcement, f_{yt} , must not exceed the yield strength of the shear studs defined in Sections 3.2.1 and 3.2.2.

4.1.2 Design Considerations: The structural design must specify the following items, based on the design requirements in this report.

- The number of shear studs per rail.
- Shear stud spacing (s)
- Shear stud overall height (H)
- Stud shank diameter (d)
- Distance between column face and first peripheral line of shear studs (S_o)
- Base rail length
- Arrangement of headed shear stud reinforcement

4.1.3 Earthquake Loads: The shear rail reinforcement may be used at slab-to-column connections of structures where a flat slab is used together with the primary seismic force-resisting systems in Seismic Design Categories C, D, E and F, such as concrete shear walls, under the following conditions:

4.1.3.1 General: Lateral force-resisting elements of the structure are designed in accordance with the IBC.

4.1.3.2 Shear Strength: The nominal shear strength provided by the concrete in the presence of the shear studs, referenced in Section 22.6.6.1 of ACI 318, must be revised as follows:

$$V_c = 1.5\lambda\sqrt{f'_c}(b_0d)$$

This revision requires revisions to the nominal shear strength, V_n , and the maximum shear stress, v_n .

Two-way slabs without beams designated as part of the seismic-force-resisting system shall comply with the provisions in Section 18.4.5.8 of ACI 318, except that V_c must be limited as set forth in Section 4.1.3.2 of this report.

Two-way slabs without beams, which are not designated as part of the seismic force-resisting system, must comply with the provisions in Section 18.14.5.1 of ACI 318, except that V_c must be limited as set forth in Section 4.1.3.2 of this report and the design story drift ratio specified in Section 18.14.5.1 of ACI 318 must not exceed the drift ratio referenced in Table 12.12-1 of ASCE/SEI 7-16 (ASCE/SEI 7-10 for the 2009 IBC).

4.2 Installation:

Installation of the Schöck Bole SR Stud Rails must comply with the applicable provisions of the 2018, 2015, 2012 and 2009 IBC and the approved engineering plans. The Schöck Bole SR Stud Rails must be positioned correctly around columns and set in accordance with the IBC and the approved engineering plans and details. Concrete cover must comply with Section 20.6.1.3.5 of ACI 318. See Figure 2 for typical installation details and dimensions.

4.3 Special Inspection:

Special inspection of shear rail reinforcement and its installation at the jobsite must comply with Section 1705.3 for the 2018, 2015 and 2012 IBC (Section 1704.4 for the 2009). The special inspector is responsible for verifying identification of the stud rail assembly per Section 7.1 of this report, along with its condition, location, positioning, clearances and clear cover.

5.0 CONDITIONS OF USE

The Schöck Bole SR Stud Rails described in this report comply with, or are suitable alternatives to what is specified

in, those codes listed in Section 1.0 of this report, subject to the following conditions:

- 5.1** The Schöck Bole SR Stud Rails must be designed, manufactured, and installed in accordance with this report and the approved plans. In the event of conflict between this report and the approved plans, the more restrictive governs.
- 5.2** Design details and drawings must be in compliance with the design requirements of Section 4.1 of this report and must be approved by the code official. The calculations and drawings must be prepared by a registered design professional when required by the statutes of the jurisdiction in which the project is to be built.
- 5.3** Special inspections must be provided in accordance with Section 4.3 of this report.
- 5.4** Schöck Bole Studs Rails are manufactured at a Schöck facility in Hungary, under a quality-control program with third-party inspections by ICC-ES.

6.0 EVIDENCE SUBMITTED

Data in accordance with the ICC-ES Acceptance Criteria for Headed Shear Stud Reinforcement Assemblies for Concrete Slabs or Footings (AC395), dated June 2017, Editorially Revised November 2017.

7.0 IDENTIFICATION

- 7.1** The Schöck Bole SR Stud Rails are identified by a stamp on the underside head of the stud with product nomenclature (SN##NA). The Schöck Bole SR Stud Rails are identified on packaging with the manufacturer's name (Schöck), part name (Bole), part size and the evaluation report number (ESR-4656).
- 7.2** The report holder's contact information is the following:

SCHÖCK USA, INC.
281 WITHERSPOON STREET
SUITE 110
PRINCETON, NEW JERSEY 08540
(855) 572-4625
www.schoeck.com



FIGURE 1—SCHÖCK BOLE SR STUD RAILS

TABLE 1—SCHÖCK BOLE SR STUD RAIL DIMENSIONS

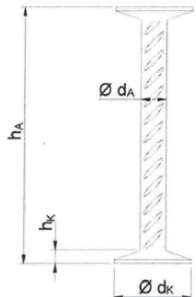
Nomenclature	Stud Diameter d_A ¹	Stud Cross-Sectional Area	Head Diameter d_K	Head Area H_A	Head Thickness h_K	Available Lengths h_A	
	in. (mm)	in ² (mm ²)	in. (mm)	in ² (mm ²)	in. (mm)	in. (mm)	
S10NA	3/8 (10)	0.122 (79)	1.25 (32)	1.25 (804)	0.276 (0.7)	5-1/8 – 27-1/2 (130 – 700)	
S12NA	1/2 (12)	0.175 (113)	1.50 (40)	1.95 (1257)	0.335 (8.5)	5-1/8 – 27-1/2 (130 – 700)	
S16NA	5/8 (16)	0.312 (201)	2.00 (51)	3.17 (2043)	0.433 (11)	6-3/4 – 55 1/8 (160 - 1400)	
S20NA	3/4 (20)	0.487 (314)	2.50 (64)	4.99 (3217)	0.512 (13)	7-7/8 – 55-1/8 (200 - 1400)	

¹The Bole stud is manufactured to the metric units in parentheses.

TABLE 2—APPLICABLE ACI 318 SECTION REFERENCES

TOPIC	ACI 318-14 (2018 and 2015 IBC)	ACI 318-11 & -08 (2012 and 2009 IBC)
Reference to ASTM A1044	20.5	3.5.5
Detailing (concrete cover)	20.6.1.3.5	7.7.5
General Design & Detailing Requirements	8.7.7.1, 8.7.7.1.1 & 22.6.8.1	11.11.5
	22.6.6.1, 22.6.6.2, 22.6.8.2 & 22.6.8.3	11.11.5.1
	8.7.7.1.2	11.11.5.2
	8.7.7.1.2	11.11.5.3
	22.6.4.2 & 22.6.6.1	11.11.5.4
Seismic Detailing	18.4.5.8	21.3.6.8
	18.14.2.1 & 18.14.5.1	21.13.6

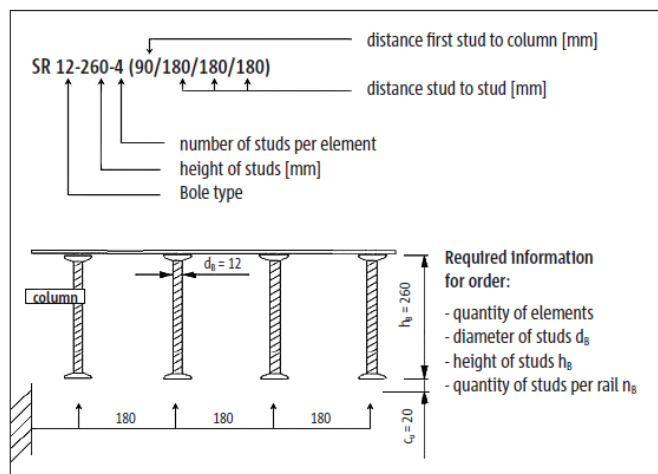

FIGURE 2—SCHÖCK BOLE SR STUD RAIL INSTALLATION

DIVISION: 03 00 00—CONCRETE
Section: 03 15 00—Concrete Accessories
Section: 03 21 00—Reinforcing Bars

REPORT HOLDER:

SCHÖCK USA, INC.

EVALUATION SUBJECT:

SCHÖCK BOLE SR STUD RAILS

1.0 REPORT PURPOSE AND SCOPE**Purpose:**

The purpose of this evaluation report supplement is to indicate that Schöck Bole SR Stud Rails, described in ICC-ES evaluation report ESR-4656, have also been evaluated for compliance with the code noted below.

Applicable code edition:

- 2019 *California Building Code* (CBC)

For evaluation of applicable chapters adopted by the California Office of Statewide Health Planning and Development (OSHPD) and Division of State Architect (DSA), see Sections 2.1.1 and 2.1.2 below.

2.0 CONCLUSIONS**2.1 CBC:**

The Schöck Bole SR Stud Rails, described in Sections 2.0 through 7.0 of the evaluation report ESR-4656, comply with CBC Chapter 19, provided the design and installation are in accordance with the 2018 *International Building Code*® (IBC) provisions noted in the evaluation report and the additional requirements of CBC Chapters 16, 17 and 19, as applicable.

2.1.1 OSHPD:

The applicable OSHPD Sections and Chapters of the CBC are beyond the scope of this supplement.

2.1.2 DSA:

The applicable DSA Sections and Chapters of the CBC are beyond the scope of this supplement.

This supplement expires concurrently with the evaluation report, reissued April 2022.